

OWNER
Henry Kostyk E. Inc.
P.O. BOX 71
SELLERSVILLE, PA 18960

PARCEL SUMMARY
T.M.P. 39-005-286 SELLERSVILLE BOROUGH

ZONING
ZONING DISTRICT: NC-NEIGHBORHOOD COMMERCIAL

REQUIRED	EXISTING	PROPOSED
LOT SIZE:	N/A	17,701 SF. (0.406 AC.)
LOT WIDTH:	N/A	35.42'
YARDS-		
FRONT:	15 FT. MIN.	58.23 FT.
SIDE:	8 FT. MIN.	1.65 FT.
REAR:	30 FT. AGG.	67.20 FT.
BUILDING HT.(FT./STORIES):	35 FT. MAX./2-1/2	3-1/2 STORES
BLDG. COVERAGE:	40%	16.3%
		2-1/2 STORES
		16.3%

PARKING
ONE SPACE FOR EACH 200 SQ. FT. OF GROSS FLOOR AREA, PLUS ONE SPACE FOR EACH 400 SQ. FT. OF GROSS FLOOR AREA ABOVE THE GROUND FLOOR.
REQUIRED: (144 FLOOR: 2,685 SF./200 = 13.4) 14
(2ND FLOOR: 2,685 SF./400 = 6.7) 7
TOTAL = 21 SPACES REQUIRED

WAWER REQUESTED:
A) \$15-20-C5 - REGARDING PARKING LOT DIMENSIONS SHALL BE NO LESS THAN TEN (10) FEET IN WIDTH BY TEN (10) FEET IN DEPTH.

NOTES
1. CONSTRUCTION DRAWINGS FOR THE PROPOSED ADA RAMP SHALL BE SUBMITTED TO THE TOWNSHIP FOR REVIEW PRIOR TO THE ISSUANCE OF A BUILDING PERMIT.

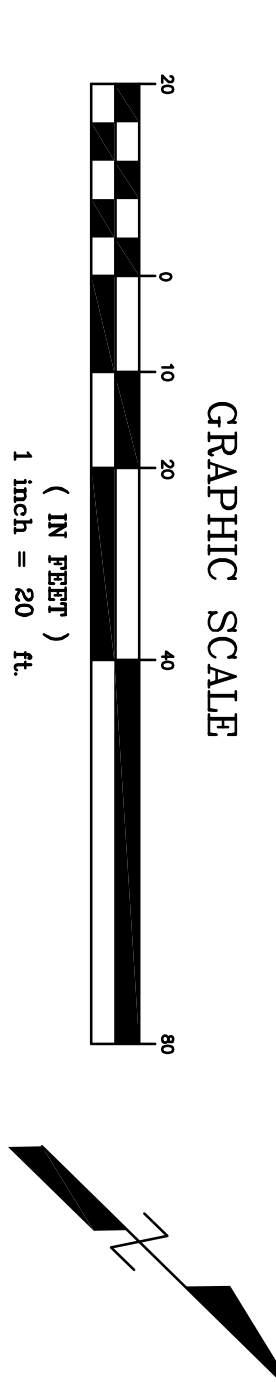
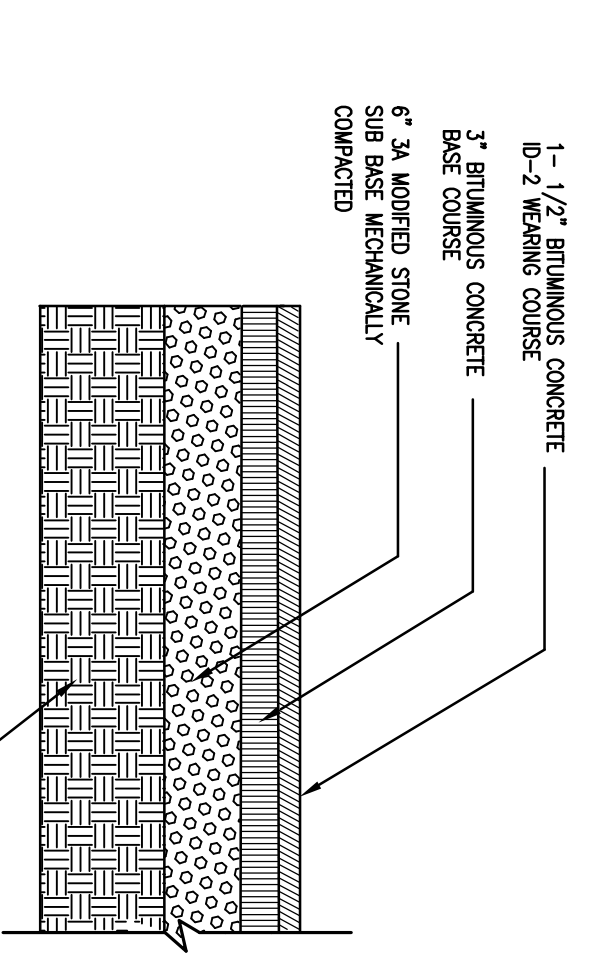
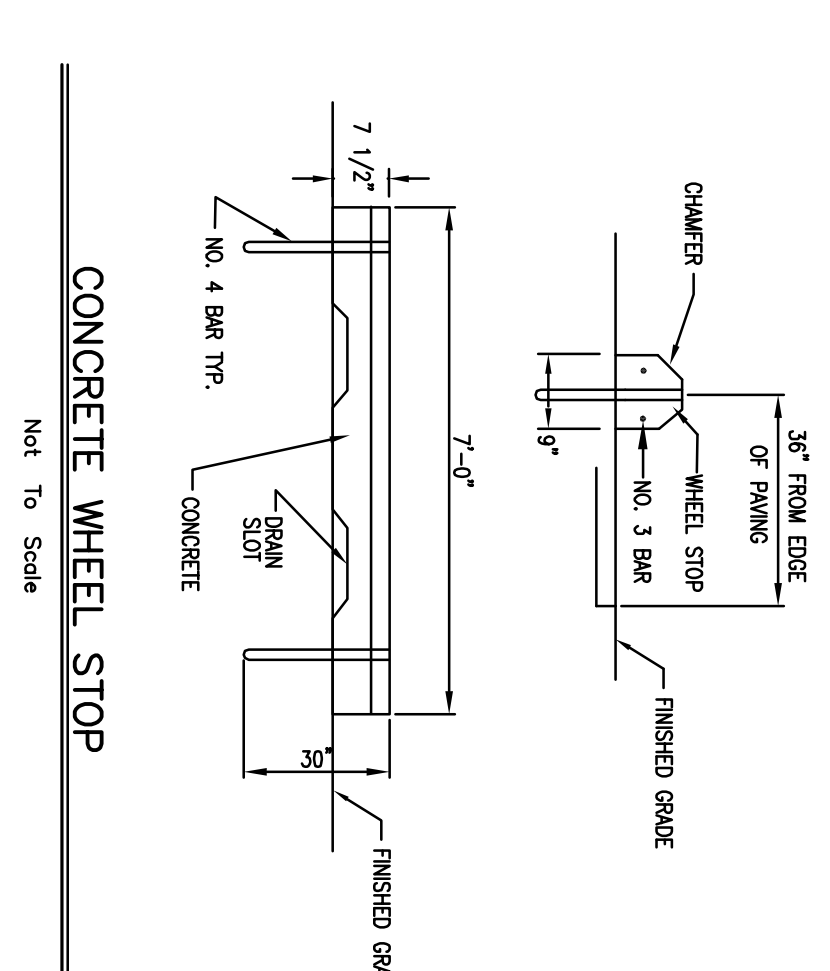
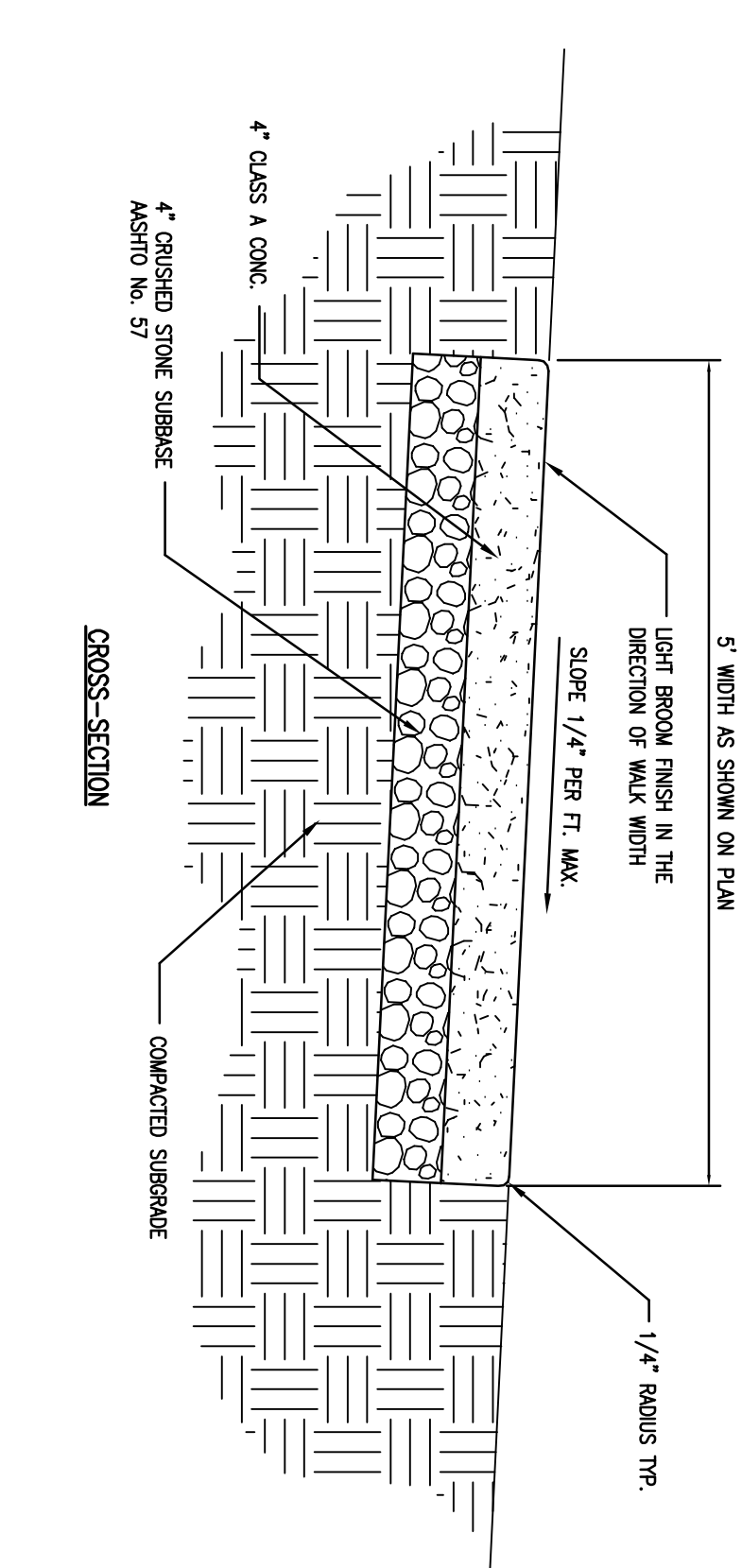
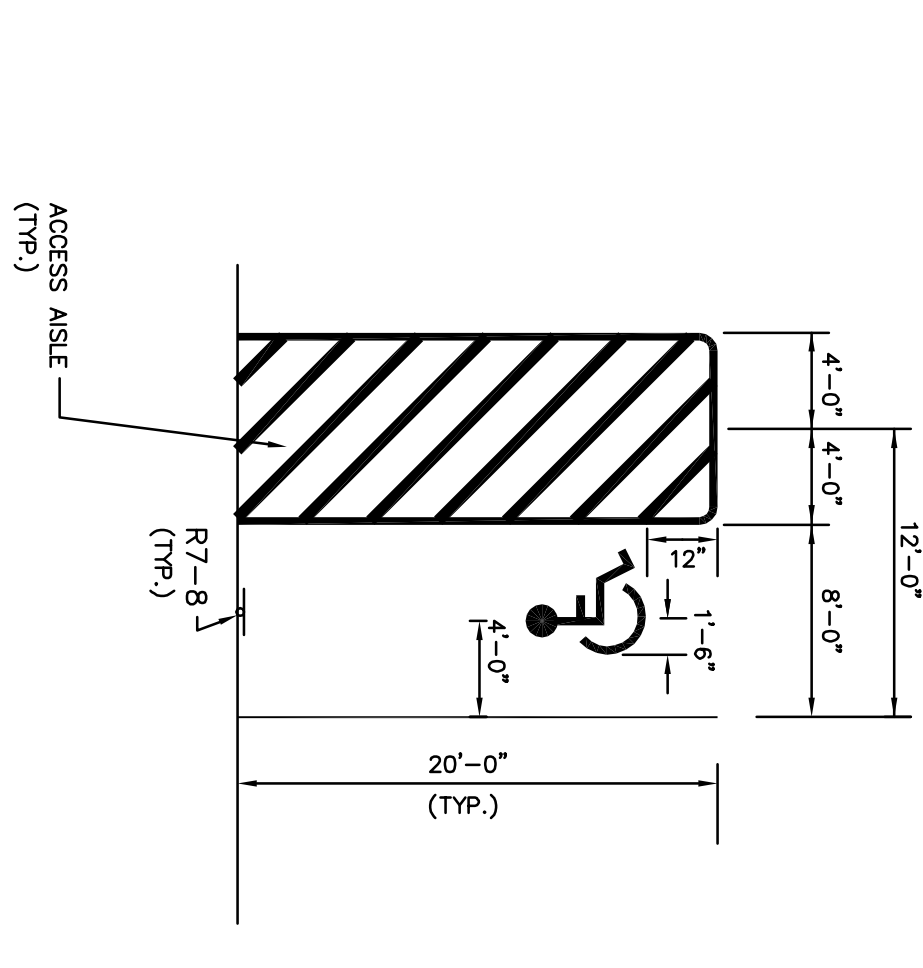

CALL BEFORE YOU DIG!
PENNSYLVANIA LAW REQUIRES 3 WORKING DAYS NOTICE FOR CONSTRUCTION PHASE AND 10 WORKING DAYS IN DESIGN STAGE-STOP CALL. PENNSYLVANIA ONE CALL SYSTEM, INC. 1-800-242-1776

REVISIONS

DATE	COMMENT
7-3-08	PER COWAN LETTER OF 6-25-08
5-8-08	PER COWAN LETTER OF 3-13-08
3-6-08	PER COWAN LETTER OF 3-29-07
8-23-07	PER COWAN LETTER OF 6-5-07

SITE PLAN

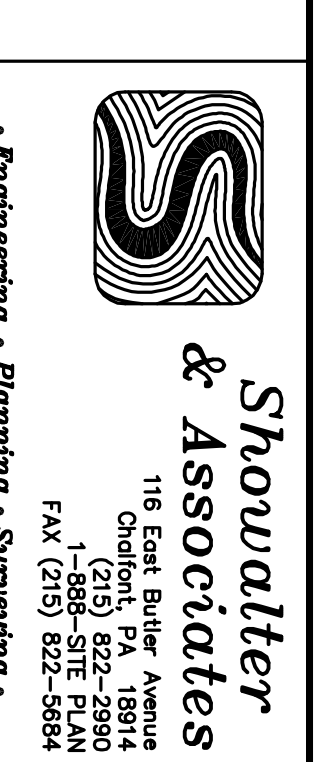

Showalter & Associates
116 East Butler Avenue
Cheltenham, PA 18914
Tel: (610) 872-2900
Fax: (215) 822-5664

HARRY KOSTYK
95 SOUTH MAIN STREET
SELLERSVILLE, PA 18960

SHEET 1 OF 4

TMP# 39-005-286